

## Setting-up the SPEEDY module plate – quick and easy

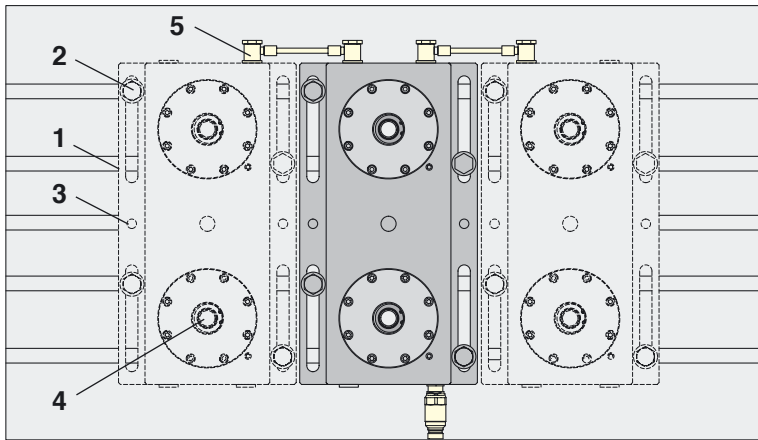

1. Align and screw on the SPEEDY module plate (1). Alignment also possible with the sliding block with pin (3) and positioning pin.
2. Move the positioning pin to the zero point (4).
3. With hole gauge (200mm), set the second and third module plates at the right or left.
4. Install the hydraulics (5).



## SPEEDY module plates – a Stark innovation

- A low-cost entry into the clamping technology
- Flexible and module extensions
- Mountable on any machine table (machine independent)
- Significant savings in setting-up
- External setting-up extends machine production cycles



## The success multipliers - SPEEDY module plates guarantee increased efficiency in production



### Synergies of Core Competences

We are members of the ROEMHELD Group and our customers benefit from the synergies created by our cooperation with other competent technology companies. The ROEMHELD Group is globally oriented and serves industrial customers all around the world.



Power workholding  
Assembly and handling  
technics  
Linear technics  
Power units



Flexible mounting systems  
Machine vice  
Tool power workholding  
Magnetic power work-  
holding



Inovativ round table  
systems



FRIEDRICHSHÜTTE

Grey cast iron and spheroidal-  
graphite cast iron



## STARK

**Zero point mounting  
systems**

Stark Spannsysteme GmbH  
Kommingerstrasse 48  
A-6840 Götzis  
Tel.: ++43 (0)5523 64 739-0  
Fax: ++43 (0)5523 64 739-7  
E-Mail: [verkauf@stark-inc.com](mailto:verkauf@stark-inc.com)  
[www.stark-inc.com](http://www.stark-inc.com)